

EASTERN ARCHITECTURAL SYSTEMS

SERIES HRP 1000F HORIZONTAL ROLLER - LMI

INSTALLATION ANCHORAGE DETAILS

PROJECT NUMBER: 415-0511	
	DATE: 6/12/15
	REVISION: A
	DESCRIPTION: UPDATED TO 5TH EDITION (2014) FBC
	BY: JBH

EASTERN ARCHITECTURAL SYSTEMS
10030 BAVARIA ROAD
FORT MYERS, FL 33913

TITLE: SERIES HRP 1000F XOX HORIZONTAL ROLLER
111" x 72" - LMI

GENERAL AND INSTALLATION NOTES

DATE: 09/25/12
DRAWING NO: EAS0002
SHEET: 1 OF 6

PREPARED BY: TJH
SCALE: N.T.S.
REV: A

PTC
PTC PRODUCT DESIGN GROUP, LLC
PO BOX 520775
LONGWOOD, FLORIDA 32752
Phone: 321.690.1788
Fax: 321.690.1789
Email: info@ptc-corp.com

GENERAL NOTES:

1. THE PRODUCT SHOWN HEREIN IS DESIGNED TO COMPLY WITH THE CURRENT EDITION OF THE FLORIDA BUILDING CODE (FBC) INCLUDING THE HIGH VELOCITY HURRICANE ZONE (HVHZ) AT THE DESIGN PRESSURES STATED HEREIN.
2. THE PRODUCT DETAILS CONTAINED HEREIN ARE BASED UPON SIGNED AND SEALED TEST REPORT(S) NO. ESP009274P, ESP009274P-1, ESP009274P-2, ESP009274P-5, ESP009274P-6 AND ESP009274P-7 AND ASSOCIATED LABORATORY DRAWINGS.
3. ADEQUACY OF THE EXISTING STRUCTURAL CONCRETE / MASONRY AND 2X FRAMING AS A MAIN WIND FORCE RESISTING SYSTEM CAPABLE OF WITHSTANDING AND TRANSFERRING APPLIED PRODUCT LOADS TO THE STRUCTURE IS THE RESPONSIBILITY OF THE ARCHITECT OR ENGINEER OF RECORD.
4. 1X AND 2X BUCKS (WHEN USED) SHALL BE DESIGNED AND ANCHORED TO PROPERLY TRANSFER ALL LOADS TO THE STRUCTURE. BUCK DESIGN AND INSTALLATION IS THE RESPONSIBILITY OF THE ARCHITECT OR ENGINEER OF RECORD.
5. THE INSTALLATION DETAILS DESCRIBED HEREIN ARE GENERIC AND MAY NOT REFLECT ACTUAL CONDITIONS FOR A SPECIFIC SITE. IF SITE CONDITIONS CAUSE INSTALLATION TO DEVIATE FROM THE REQUIREMENTS DETAILED HEREIN, SITE SPECIFIC DOCUMENTS SHALL BE PREPARED FOR USE WITH THIS DOCUMENT.
6. THIS PRODUCT COMPLIES WITH THE REQUIREMENTS OF THE HIGH VELOCITY HURRICANE ZONE (HVHZ) FOR OPENING PROTECTION OF THE CURRENT EDITION OF THE FLORIDA BUILDING CODE AND DOES NOT REQUIRE AN IMPACT RESISTANT COVERING.
 - 6.1. FOR INSTALLATION 30 FT. ABOVE GRADE, ALL UNITS MUST BE SAFETY GLAZED OR COVERED BY AN IMPACT PROTECTIVE SYSTEM MEETING THE REQUIREMENTS OF THE CURRENT EDITION OF THE FLORIDA BUILDING CODE.
7. WHEN USED IN AREAS OUTSIDE OF THE HIGH VELOCITY HURRICANE ZONE (HVHZ) REQUIRING WIND BORNE DEBRIS PROTECTION, THE OPENING PROTECTION REQUIREMENTS OF THE CURRENT EDITION OF THE FLORIDA BUILDING CODE ARE MET. AN IMPACT RESISTANT COVERING IS NOT REQUIRED. THIS PRODUCT MEETS MISSILE LEVEL "D" AND INCLUDES WIND ZONE 4 AS DEFINED IN ASTM E 1996 AS MODIFIED BY THE CURRENT EDITION OF THE FLORIDA BUILDING CODE.
8. MATERIALS
 - 8.1. WINDOW FRAME MATERIAL: EXTRUDED ALUMINUM 6063-T6 0.063" THICK.
 - 8.2. WINDOW SASH MATERIAL: EXTRUDED ALUMINUM 6063-T6 0.062" THICK.
9. GLASS MEETS THE REQUIREMENTS OF ASTM E1300-04e1 GLASS CHARTS. SEE SHEET 5 AND 6 FOR GLAZING DETAILS.
10. DESIGNATIONS "X" AND "O" STAND FOR THE FOLLOWING (AS APPLICABLE):
 - 10.1. X: OPERABLE SASH
 - 10.2. O: FIXED SASH
11. IN ACCORDANCE WITH THE CURRENT EDITION OF THE FLORIDA BUILDING CODE, WOOD SHALL HAVE BEEN PRESERVATIVE TREATED OR SHALL BE OF A DURABLE SPECIES.
12. ALL UNITS UNDER THIS APPROVAL SHALL USE SETTING BLOCKS IN COMPLIANCE WITH THE CURRENT EDITION OF THE FLORIDA BUILDING CODE WHEN APPLICABLE.

INSTALLATION NOTES:

1. ONE (1) INSTALLATION ANCHOR IS REQUIRED AT EACH ANCHOR LOCATION SHOWN.
2. THE NUMBER OF INSTALLATION ANCHORS DEPICTED IS THE MINIMUM NUMBER OF ANCHORS TO BE USED FOR PRODUCT INSTALLATION.
3. ANCHORS ARE TO MATCH TYPE, SIZE, EDGE DISTANCE AND EMBEDMENT OF THOSE SHOWN IN THE INSTALLATION ANCHOR SCHEDULE SHOWN ON THIS SHEET FOR THE RESPECTIVE SUBSTRATE.
4. SHIM AS REQUIRED AT EACH INSTALLATION ANCHOR WITH LOAD BEARING SHIM(S). MAXIMUM ALLOWABLE SHIM SIZE IS 1/4 INCH. SHIM WHERE SPACE OF 1/16 INCH OR GREATER OCCURS. SHIM(S) SHALL BE CONSTRUCTED OF HIGH DENSITY PLASTIC OR BETTER.
5. MINIMUM EMBEDMENT AND EDGE DISTANCE EXCLUDE WALL FINISHES (INCLUDING BUT NOT LIMITED TO STUCCO, FOAM, BRICK VENEER, AND SIDING).
6. INSTALLATION ANCHORS AND ASSOCIATED HARDWARE MUST BE MADE OF CORROSION RESISTANT MATERIAL OR HAVE A CORROSION RESISTANT COATING. DISSIMILAR METALS INCLUDING FASTENERS THAT MAY COME INTO CONTACT WITH ALUMINUM FRAMING SHALL HAVE BEEN PROTECTED.
7. FOR HOLLOW BLOCK AND GROUT FILLED BLOCK, DO NOT INSTALL INSTALLATION ANCHORS INTO MORTAR JOINTS. EDGE DISTANCE IS MEASURED FROM FREE EDGE OF BLOCK OR EDGE OF MORTAR JOINT INTO FACE SHELL OF BLOCK.
8. INSTALLATION ANCHORS SHALL BE INSTALLED IN ACCORDANCE WITH ANCHOR MANUFACTURER'S INSTALLATION INSTRUCTIONS. ANCHORS SHALL NOT BE USED IN SUBSTRATES WITH STRENGTHS LESS THAN THE MINIMUM STRENGTH SPECIFIED IN THE INSTALLATION ANCHOR SCHEDULE ON THIS SHEET.

DESIGN PRESSURE RATING (PSF)	IMPACT RATING
+60.0/-60.0	LARGE MISSILE

ANCHOR SCHEDULE							
SUBSTRATE	INSTALLATION TYPE	SCREW HEAD TYPE	SCREW SIZE	MANUFACTURER AND/OR SPECIFICATION	EMBEDMENT (IN) ^{(2) (3)}	EDGE DISTANCE (IN) ^{(2) (3)}	ANCHOR CAPACITIES BASED ON
CONCRETE	THRU-FRAME	FLAT OR PAN HEAD	3/16"	ITW TAPCONS ⁽¹⁾	1-1/2"	1-1/8"	MIN. 2000 PSI CONCRETE
MASONRY (BLOCK/CMU)	THRU-FRAME	FLAT OR PAN HEAD	3/16"	ITW TAPCONS ⁽¹⁾	1"	2"	STRENGTH CONFORMANCE TO ASTM C-90, MEDIUM WEIGHT
WOOD	THRU-FRAME	FLAT OR PAN HEAD	NO. 10	ANSI B18.6.1 (WOOD SCREW)	1-3/8"	3/4"	WOOD WITH A MINIMUM SPECIFIC GRAVITY OF 0.55.
		FLAT OR PAN HEAD	No. 10	ASME B18.6.4 (TAPPING SCREW)			

- NOTES:**
- 1) ITW (ADVANCED THREADFORM TECHNOLOGY) TAPCONS WILL BE USED FOR CONCRETE/MASONRY INSTALLATION.
 - 2) FOR WOOD SCREWS IF SPLITTING IS A CONCERN, DRILL 0.112" (34 DRILL SIZE) PILOT HOLE FOR NO. 10 WOOD SCREW.
 - 3) FOR TAPPING SCREWS IF SPLITTING IS A CONCERN, DRILL 0.121" (31 DRILL SIZE) PILOT HOLE FOR NO. 10 TAPPING SCREW.

TABLE OF CONTENT	
SHEET	DESCRIPTION
1	GENERAL AND INSTALLATION NOTES
2 - 3	ELEVATION AND ANCHORING LAYOUT
4	VERTICAL CROSS SECTION AND GLAZING DETAILS
5	HORIZONTAL CROSS SECTION
6	BILL OF MATERIALS AND COMPONENTS

Robert J. Amoruso, P.E.
FL P.E. No. 49752

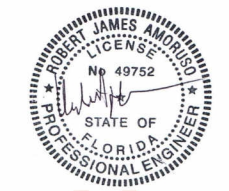

Digitally signed by Robert J. Amoruso
DN: cn=Robert J. Amoruso, o=PTC Product Design Group, email=robert@ptc-corp.com, c=US
Date: 2015.06.14 16:36:43 -04'00'

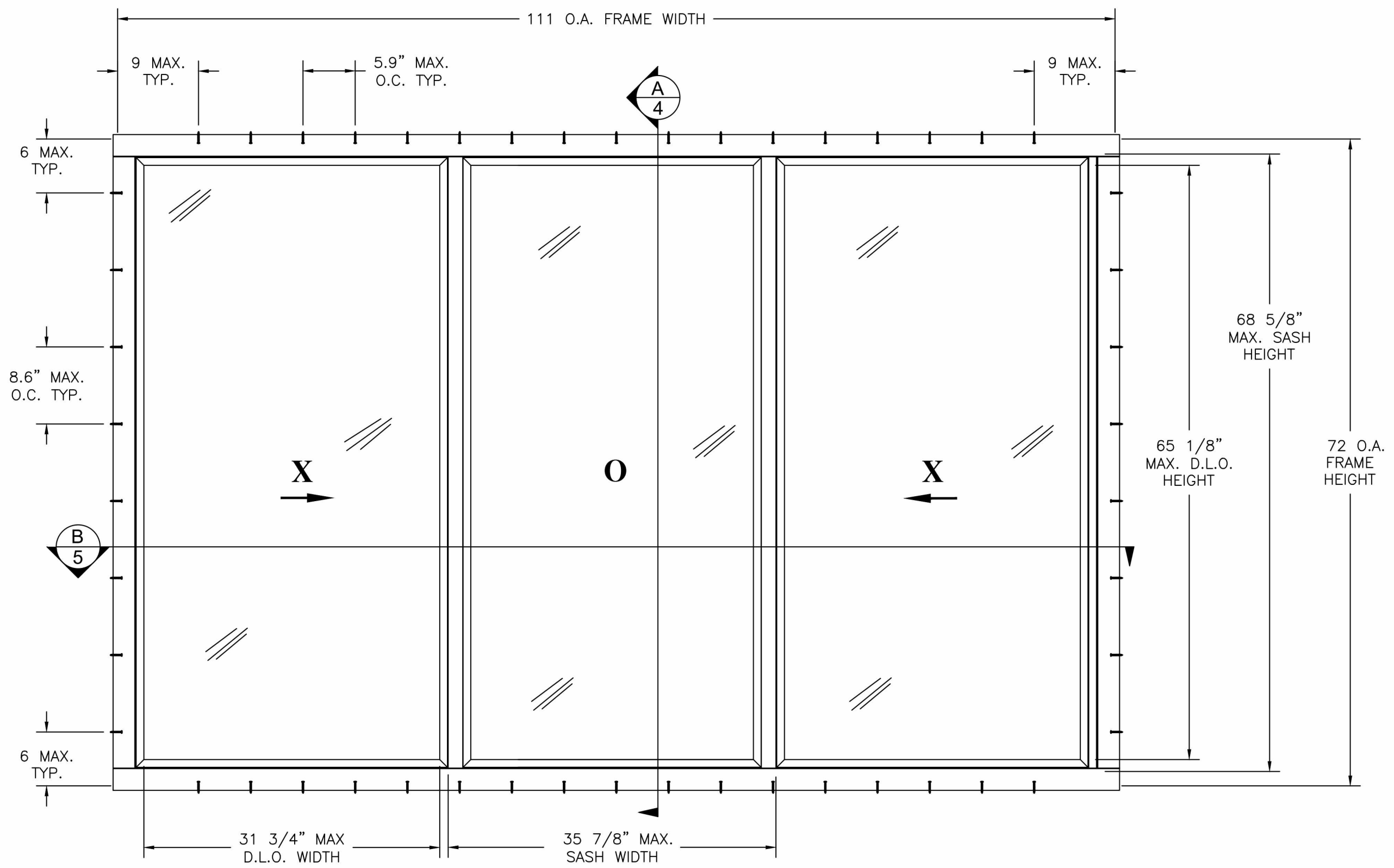

**SERIES HR 1000F EQUAL LITE
HORIZONTAL ROLLING WINDOW**

EXTERIOR VIEW
UNIT APPROVED WITH GLAZING DETAILS 1 AND 2 ONLY
BILL OF MATERIALS ITEMS #8 AND #9

PROJECT NUMBER:	415-0511
DATE	6/12/15
DESCRIPTION	UPDATED TO 5TH EDITION (2014) FBC
REV	A
BY	JBH

EASTERN ARCHITECTURAL SYSTEMS
10030 BAVARIA ROAD
FORT MYERS, FL33913

TITLE: SERIES HRP 1000F XOX HORIZONTAL ROLLER
111" x 72" - LMI
EQUALLITE ELEVATION AND ANCHORING LAYOUT

PREPARED BY: TJH
DATE: 09/25/12
SCALE: N.T.S.
DRAWING NO: EAS0002
SHEET: 2 OF 6

PTC PRODUCT DESIGN GROUP, LLC
PO BOX 520775
LONGWOOD, FLORIDA 32752
Phone: 321.690.1788
Fax: 321.690.1789
Email: info@ptc-corp.com



Robert J. Amoruso, P.E.
FL P.E. No. 49752

Digitally signed by Robert J. Amoruso
DN: cn=Robert J. Amoruso, o, ou=PTC Product Design Group, email=robert@ptc-corp.com, c=US
Date: 2015.06.14 16:37:04 -04'00'

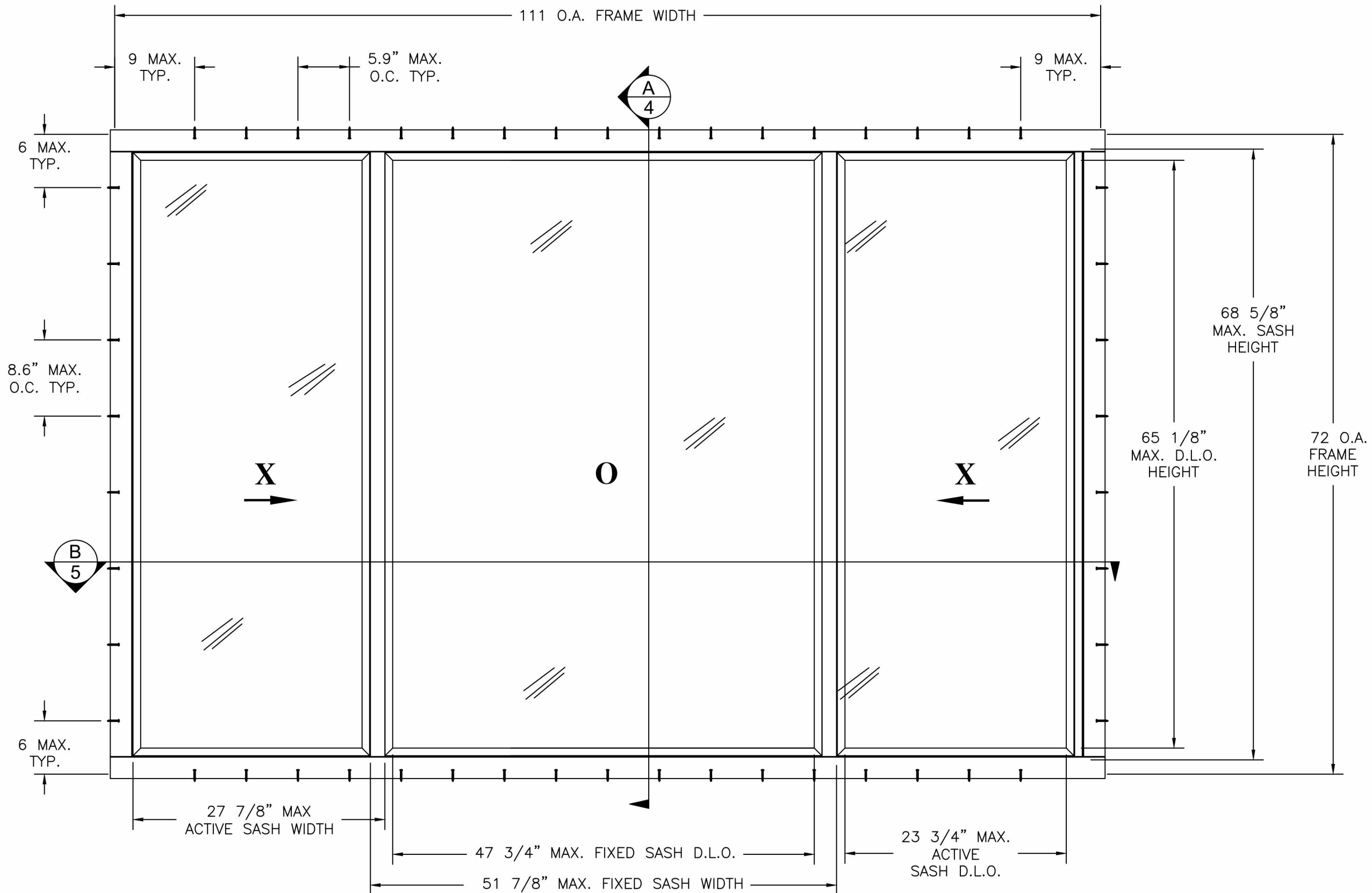

**SERIES HR 1000F UNEQUAL LITE
HORIZONTAL ROLLING WINDOW**

EXTERIOR VIEW
UNIT APPROVED WITH GLAZING DETAIL 1 ONLY
BILL OF MATERIALS ITEM #8

PROJECT NUMBER:	415-0511		
REV	DESCRIPTION	DATE	BY
A	UPDATED TO 5TH EDITION (2014) FBC	6/12/15	JBH

EASTERN ARCHITECTURAL SYSTEMS
10030 BAVARIA ROAD
FORT MYERS, FL33913

TITLE: SERIES HRP 1000F XOX HORIZONTAL ROLLER
111" x 72" - LMI
UNEQUAL LITE ELEVATION AND ANCHORING LAYOUT

PREPARED BY: TJH
DATE: 09/25/12
SCALE: N.T.S.
DRAWING NO: EAS0002
SHEET: 3 OF 6

PTC PRODUCT DESIGN GROUP, LLC
PO BOX 520775
LONGWOOD, FLORIDA 32752
Phone: 321.690.1788
Fax: 321.690.1789
Email: info@ptc-corp.com



Robert J. Amoruso, P.E.
FL P.E. No. 49752

Digitally signed by Robert J. Amoruso
DN: cn=Robert J. Amoruso, o=PTC Product Design Group, email=robert@ptc-corp.com, c=US
Date: 2015.06.14 16:37:23 -04'00'

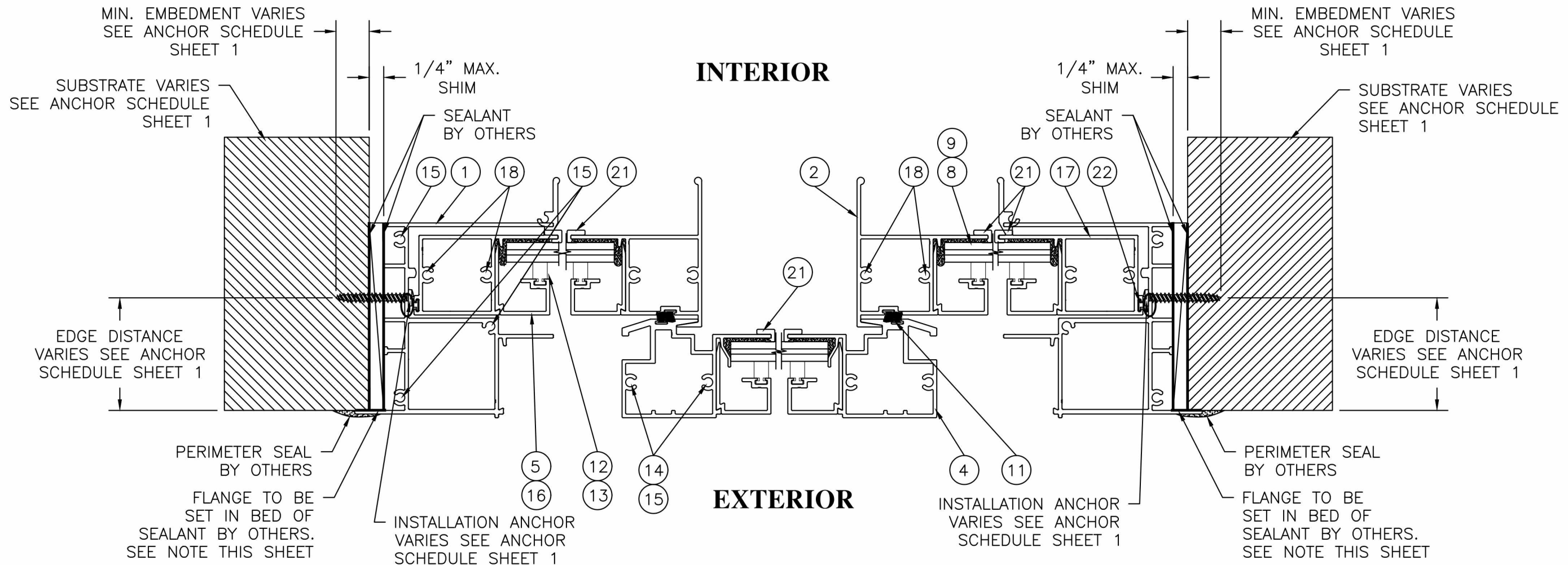

B **HORIZONTAL CROSS SECTION**
5 **INSTALLATION**

FLANGE NOTE:
 THE FLANGE IS A NON-STRUCTURAL PART. IT MAY BE TRIMMED SHORT OR REMOVED ALL TOGETHER DEPENDING ON INSTALLATION REQUIREMENTS.

PROJECT NUMBER:	415-0511
DATE	6/12/15
DESCRIPTION	UPDATED TO 5TH EDITION (2014) FBC
REV	A
BY	JBH

EASTERN ARCHITECTURAL SYSTEMS
 10030 BAVARIA ROAD
 FORT MYERS, FL 33913

TITLE: SERIES HRP 1000F XOX HORIZONTAL ROLLER
 111" x 72" - LMI
 HORIZONTAL CROSS SECTION

PREPARED BY: TJH
 DATE: 09/25/12
 SCALE: N.T.S.
 DRAWING NO: EAS0002
 SHEET: 5 OF 6

PTC PRODUCT DESIGN GROUP, LLC
 PO BOX 520775
 LONGWOOD, FLORIDA 32752
 Phone: 321.690.1788
 Fax: 321.690.1789
 Email: info@ptc-corp.com
 FBPE C.A. NO. 25935

Robert J. Amoruso, P.E.
 FL P.E. No. 49752

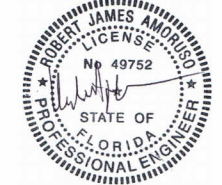

Digitally signed by Robert J. Amoruso
 DN: cn=Robert J. Amoruso, o, ou=PTC Product Design Group, email=robert@ptc-corp.com, c=US
 Date: 2015.06.14 16:37:57 -04'00'

BILL OF MATERIALS

ITEM #	PART NUMBER	DESCRIPTION	MANUFACTURER	MATERIAL
1	GAH-49665	NEW IMPACT HR SILL	INDALEX AMERICA, INC.	ALUMINUM 6063-T6
2	GAH-48982	NEW IMPACT SH VENT HEAD	INDALEX AMERICA, INC.	ALUMINUM 6063-T6
3	GAS-46856	IMPACT VENT JAMB	INDALEX AMERICA, INC.	ALUMINUM 6063-T6
4	GAH-48984	IMPACT MEETING RAIL	INDALEX AMERICA, INC.	ALUMINUM 6063-T6
5	GAS-48415	5/16" IMPACT GLAZING BEAD	INDALEX AMERICA, INC.	ALUMINUM 6063-T6
6	SERIES 1988	ROLLER ASSEMBLY	AMESBURY HARDWARE	STEEL
7		LATCH/LOCK ASSEMBLY		
8		5/16" LAMI IMPACT GLAZING DETAIL 1		
9		5/8" IGU LAMI IMPACT GLAZING DETAIL 2		
10	SIKAFLEX 552	STRUCTURAL ADHESIVE/GLAZING COMPOUND	SIKA CORPORATION	SILANE-TERMINATED POLYMER
11		FIN WEATHERSTRIPPING		
12	30228	GLAZING VINYL 5/16" GLASS		
13	30222	GLAZING VINYL 5/8" GLASS		
14		#8 x 3 1/2" PH SMS MEETING RAIL TO SILL ASSEMBLY SCREW		
15		#8 x 1" PH SMS FRAME ASSEMBLY SCREW		
16	GAS-48191	5/8" IMPACT GLAZING BEAD	INDALEX AMERICA, INC.	ALUMINUM 6063-T6
17	49652	IMPACT S.H. VENT SILL	INDALEX AMERICA, INC	ALUMINUM 6063-T6
18		#8 x 3/4" PH SMS SASH ASS'Y		
19		NOT USED		
20		5/8" IGU LAMI IMPACT GLAZING DETAIL 3		
21	RP-1009	GLAZING COMPOUND STOP	PROTOTYPE PLASTICS	VINYL
22		VINYL BULB SEAL		VINYL

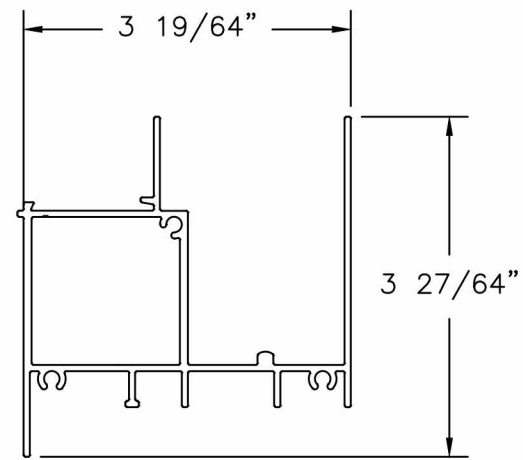

① **IMPACT HR SILL**
EXTRUDED ALUMINUM 6063-T6
0.063" THICK

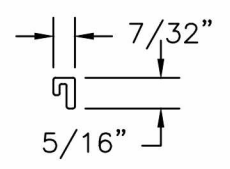

② **GLAZING COMPOUND STOP**
EXTRUDED VINYL 0.085" THICK

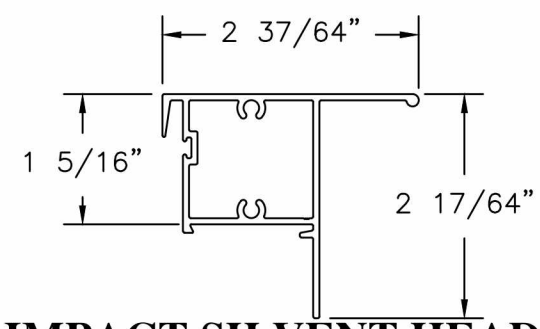

② **IMPACT SH VENT HEAD**
EXTRUDED ALUMINUM 6063-T6
0.062" THICK

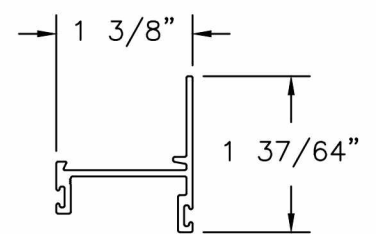

③ **IMPACT VENT JAMB**
EXTRUDED ALUMINUM 6063-T6
0.062" THICK

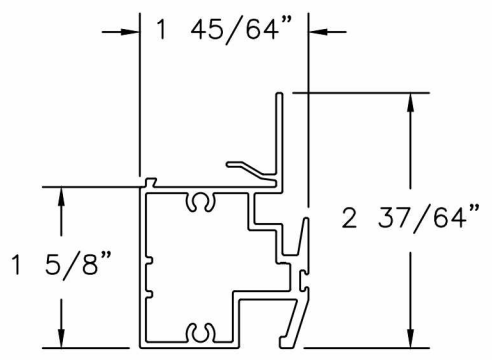

④ **IMPACT MEETING RAIL**
EXTRUDED ALUMINUM 6063-T6
0.063" THICK

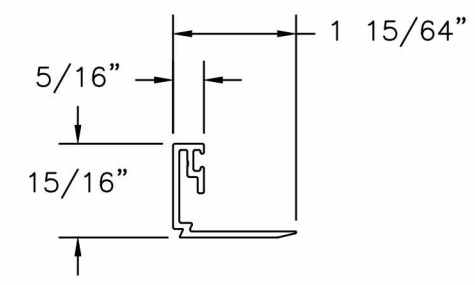

① **5/8" INS IMPACT GLAZING BEAD**
EXTRUDED ALUMINUM 6063-T6
0.062" THICK

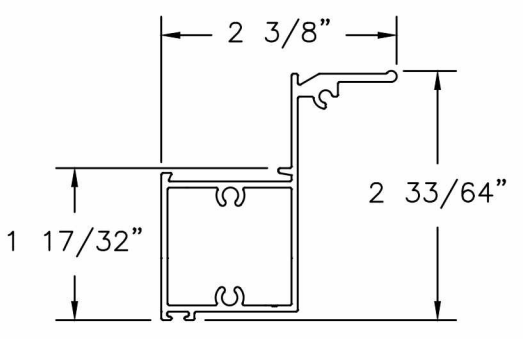

① **VENT S.H. VENT SILL**
EXTRUDED ALUMINUM 6063-T6
0.063" THICK

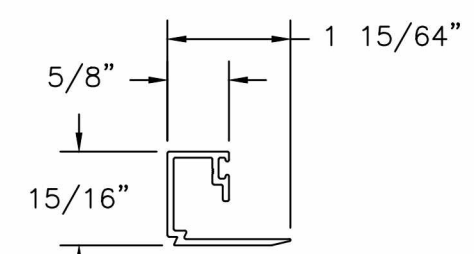

⑤ **5/16" IMPACT GLAZING BEAD**
EXTRUDED ALUMINUM 6063-T6
0.062" THICK

PROJECT NUMBER:	415-0511
DATE	6/12/15
DESCRIPTION	UPDATED TO 5TH EDITION (2014) FBC
REV	A
BY	JBH

EASTERN ARCHITECTURAL SYSTEMS
10030 BAVARIA ROAD
FORT MYERS, FL 33913

TITLE: SERIES HRP 1000F XOX HORIZONTAL ROLLER
111" x 72" - LMI
BILL OF MATERIALS AND COMPONENTS

PREPARED BY: TJH
SCALE: N.T.S.
REV: A

DATE: 09/25/12
DRAWING NO: EAS0002
SHEET: 6 OF 6

PTC PRODUCT DESIGN GROUP, LLC
PO BOX 520775
LONGWOOD, FLORIDA 32752
Phone: 321.690.1788
Fax: 321.690.1789
Email: info@ptc-corp.com

Robert J. Amoruso, P.E.
FL P.E. No. 49752

Digitally signed by Robert J. Amoruso
DN: cn=Robert J. Amoruso, o, ou=PTC Product Design Group, email=robert@ptc-corp.com, c=US
Date: 2015.06.14 16:38:13 -04'00'